

Champro®

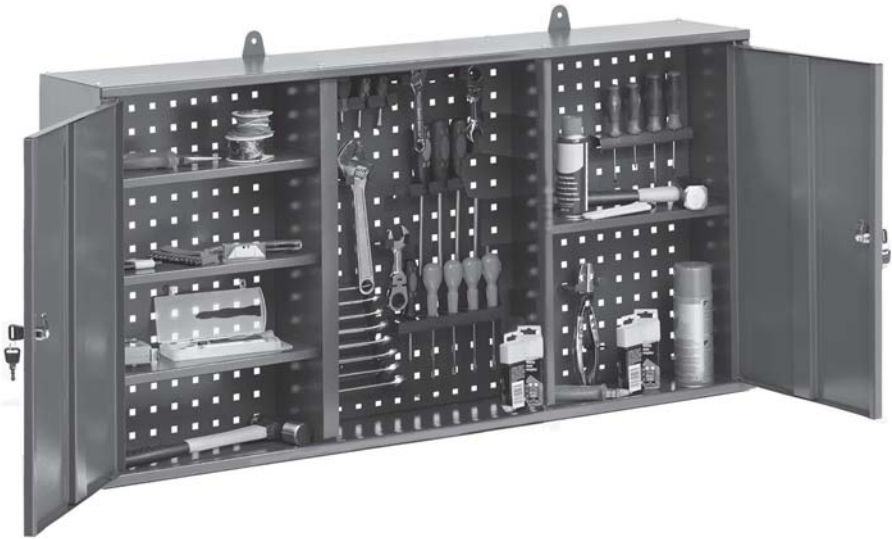

Lockable Wall Cabinet

Model: CWC50

Part No: 7640020

ASSEMBLY INSTRUCTIONS

INTRODUCTION

Thank you for purchasing this CLARKE product. Before assembling the cabinet, be sure to read these instructions thoroughly. In doing so you will ensure the safety of yourself and of others around you, and you can look forward to the product giving you long and satisfactory service.

GUARANTEE

This CLARKE product is guaranteed against faulty manufacture for a period of 12 months from the date of purchase. Please keep your receipt as proof of purchase. This guarantee is invalid if the product is found to have been abused or tampered with in any way, or not used for its intended purpose.

Faulty goods should be returned to their place of purchase, no product can be returned to us without prior permission.

This guarantee does not effect your statutory rights.

SPECIFICATIONS

Dimensions: 1210 x 203 x 590 mm

Weight: 17 kg (packed)

CONTENTS

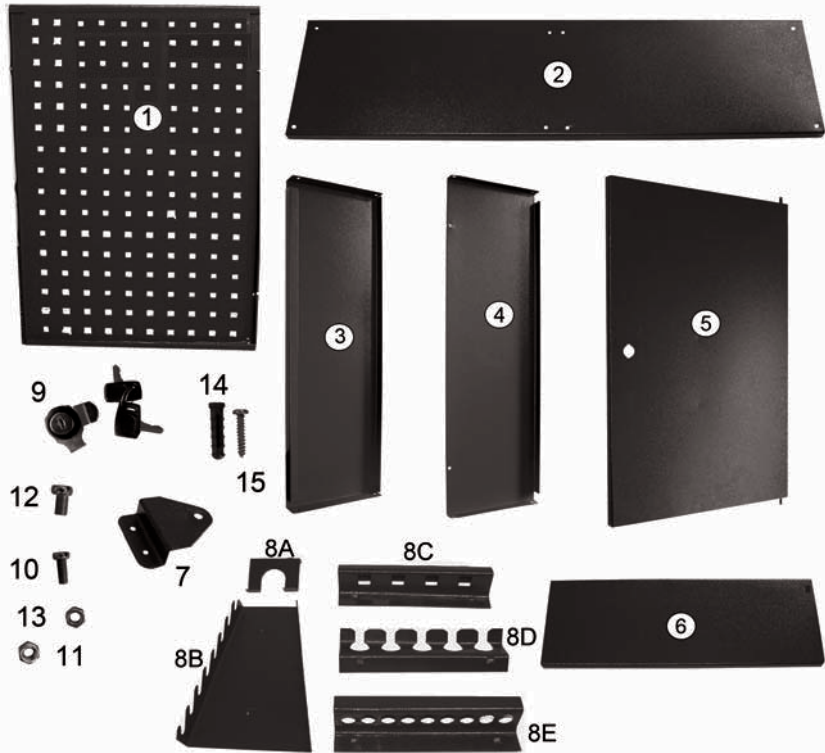

No	Description	Qty
Larger loose items		
1	Back Panel	3
2	Top/Bottom Panel	2
3	Dividing Panel	2
4	End Panel	2
5	Door Panel	2
6	Shelf Panel	4
7	Supporting Bracket	2
8	Tool Support Fittings	10

No	Description	Qty
Smaller items in sealed packet		
9	Door Lock set inc Key	2
10	Bolt (M4 x 10mm)	4
11	M4 Nut	4
12	Bolt (M5 x 10mm)	20
13	Nut M5	20
14	Wall Plug	2
15	Screw	2

SAFETY PRECAUTIONS

1. Always read the instructions before assembling the unit.
2. Periodically inspect the unit to ensure it is in good condition, replace any damaged parts.
3. If replacing any parts, use only those supplied by Clarke International, referring to the parts list on page 3.

Please keep these instructions in a safe place for future reference.

ASSEMBLY

Unpack the parts on to a clean flat area and visually inspect components to ensure that no damage was suffered in transit, identifying them according to the parts list and diagram opposite.

Should any damage be apparent, please contact your Clarke dealer immediately.

Note: When assembling, all screw heads should be on the outside of the cabinet. DO NOT tighten any nuts until the cabinet is fully assembled.

1. Hold the back panels as shown in Fig 1, with the left/right hand dividing panels slotted between them.

- Ensure that all three back panels are the same way up and check the slotted holes are oriented as shown.

Note: The back panels are of a shallow folded section. The bare edges should be towards the rear of the cabinet.

2. Line up the holes and insert an M5 bolt at each of the four locations. Secure with an M5 washer and nut as shown in Fig 2.

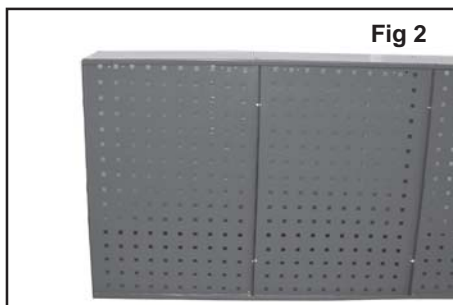
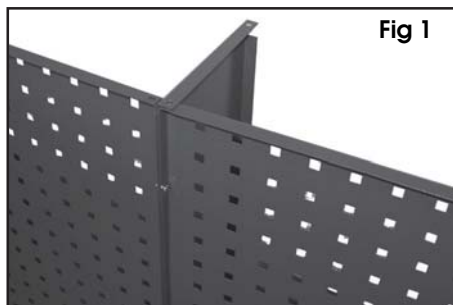

3. Place the top panel in position on the assembly as shown in Fig 3, so that the edge with the return fold lies at the front, and secure loosely to both the rear and dividing panels with an M5 bolt, washer and nut.

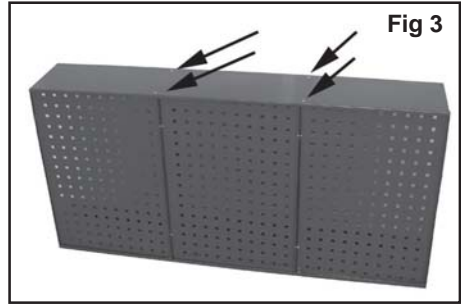

4. Lay the assembly down and offer up the bottom panel (the edge with the return fold uppermost). Attach it to the rear and dividing panels at each intersection as in Fig 4

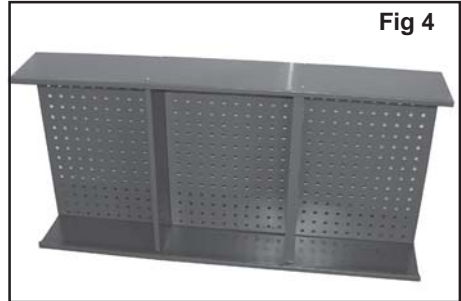

5. Offer up a side panel to one end as shown in Fig 5. Line up one of the corner holes and insert an M5 bolt and secure with a washer and nut. Repeat at the other three corners.

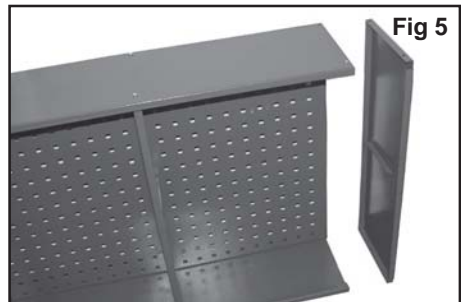

6. Fit the remaining side panel and loosely tighten the M5 bolts, 5mm washers and M5 nuts.

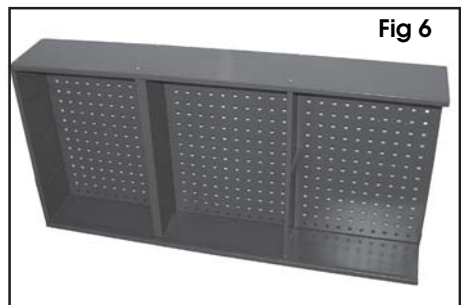

7. Attach the left hand door by inserting the pivot pins into the pivot holes in the top and bottom panels.

- When inserting the door into the pivot holes you may need to loosen some bolts to guide the door pivots into both pivot holes. Repeat with the other door.

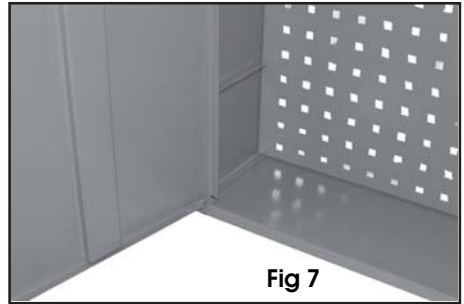

Fig 7

8. Feed the lock barrel through the door from outside as shown in Fig 8, and secure loosely in place with the nut.



Fig 8

9. Fit the locking tab to the lock barrel with the short screw and washer as shown in Fig 9.

- You can now determine whether the tab will secure the door on the up or down stroke. Locking on the down stroke is the usual choice;- you may need to re-assemble the lock and tab to achieve this.



Fig 9

10. With the cabinet lying on a level surface, wriggle it gently to ensure that no part is locally stressed, before progressively tightening all the nuts.

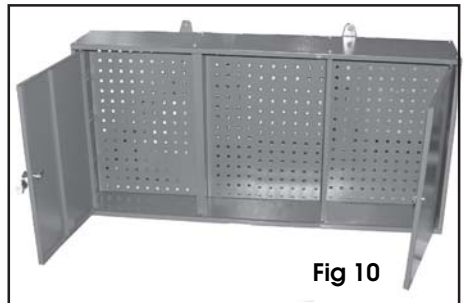
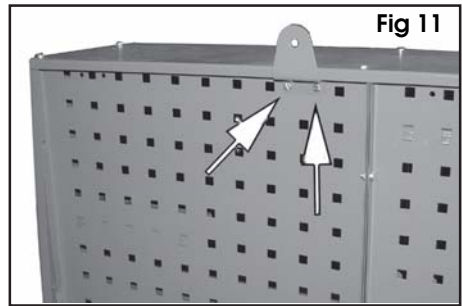

Fig 10

11. Attach the support brackets to the back panels as shown in Fig 11, using the M4 bolts, nuts and washers provided.

- The brackets should not be in the centre of the back panels but slightly towards the middle of the cabinet.



12. The shelves are placed on the brackets integral to the end/side panels.

13. Tool supports are suspended from the back panel and may be positioned to suit your requirements as shown in Fig 12, to suit any collection of tools.

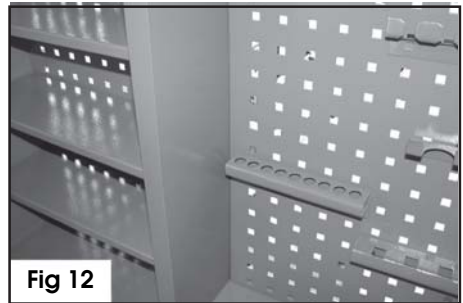

Your wall cabinet is now ready to hang. Wall plugs and screws are provided for this purpose. Ensure it is firmly attached to the wall before loading with tools.

A SELECTION FROM THE VAST RANGE OF

Clarke®

QUALITY PRODUCTS

AIR COMPRESSORS

From DIY to industrial, Plus air tools, spray guns and accessories.

GENERATORS

Prime duty or emergency standby for business, home and leisure.

POWER WASHERS

Hot and cold, electric and engine driven - we have what you need

WELDERS

Mig, Arc, Tig and Spot. From DIY to auto/industrial.

METALWORKING

Drills, grinders and saws for DIY and professional use.

WOODWORKING

Saws, sanders, lathes, mortisers and dust extraction.

HYDRAULICS

Cranes, body repair kits, transmission jacks for all types of workshop use.

WATER PUMPS

Submersible, electric and engine driven for DIY, agriculture and industry.

POWER TOOLS

Angle grinders, cordless drill sets, saws and sanders.

STARTERS/CHARGERS

All sizes for car and commercial use.



PARTS & SERVICE: 020 8988 7400

E-mail: Parts@clarkeinternational.com or Service@clarkeinternational.com

SALES: UK 01992 565333 or Export 00 44 (0)1992 565335

Clarke INTERNATIONAL Hemnall Street, Epping, Essex CM16 4LG
www.clarkeinternational.com